

Touch Sensor

By Sanjay and Arvind Seshan



BEGINNER PROGRAMMING LESSON

LESSON OBJECTIVES

1. Learn how to use the Touch Sensor
2. Learn how to use the Wait For Block
3. Learn the difference between the Wait For Block and the Sensor Blocks
4. Learn when to use Move Block's "On" mode

WHAT IS A SENSOR?

- A sensor lets an EV3 program measure and collect data about its surroundings
- The EV3 sensors include:
 - Color – measures color and darkness
 - Gyro – measures rotation of robot
 - Ultrasonic – measures distance to nearby surfaces
 - Touch – measures contact with surface
 - Infrared – measures IR remote's signals



Image from: http://www.ucalgary.ca/IOSTEM/files/IOSTEM/media_crop/44/public/sensors.jpg

© EV3Lessons.com, 2016, (Last edit: 07/04/16)

WHAT IS A TOUCH SENSOR?

- Touch Sensor can detect when the sensor's red button has been pressed or released
- With this information, you can program an action when the sensor is:

Currently Pressed

Currently Released

Pressed and Released Just Before (Bumped)

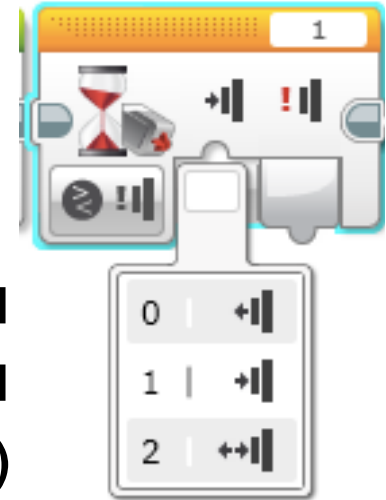

- When might you use this sensor?
 - Useful for programming “moving until touch sensor is pressed/released/bumped”
 - For example, if you put a touch sensor on the front of the robot, you can have it stop moving if it runs into something.
 - You can also have your program start or stop when a touch sensor is pressed.

WHAT DOES “BUMPED” MEAN?*

The sensor basically is like a True/False switch
“Bumped” can be tricky. What conditions must be there for the sensor to read True for Bumped?

Time	Action	Pressed	Released	Bumped
1	Button starts released	False	True	False
2	Button is pressed in	True	False	False
3	Button is released, and program reads sensor	False	True	<u>True</u>
4	Button is still released, and the program tests the Touch Sensor again	False	True	False
5	Button is pressed a second time	True	False	False
6	Button is released, but the program does not read the sensor			
200 secs later...	Program reads sensor	False	True	<u>True</u>
201	Button is still released, and the program tests the Touch Sensor again	False	True	False

* Based on the Lego EV3 help screen

HOW DO YOU PROGRAM WITH THE TOUCH SENSOR?

There is a Touch Sensor Block in the Yellow Tab, but there is a Wait for Touch in the Orange Tab. What is the difference!!?????



Yellow Sensor Tab: Sensor Blocks

- Used to Read and Compare Sensor Values

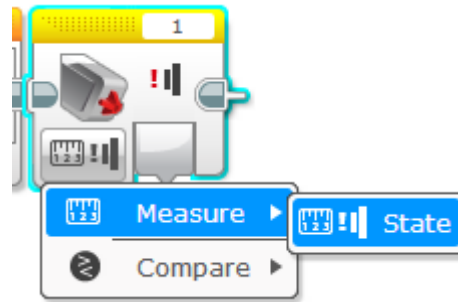

Orange Flow Tab: Wait for Block

- Used to wait for a sensor reading (or time)

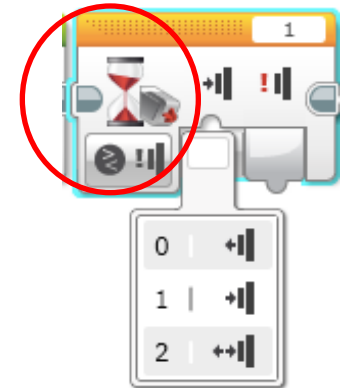

In this lesson, we will use the Wait For Block

MOVE ON AND OFF

What would happen if you placed a Move Steering Block and left the motor “On”?

Would the robot...

- 1) Move?
- 2) Move for a little while?
- 3) Not move at all?

ANS. Not move at all.

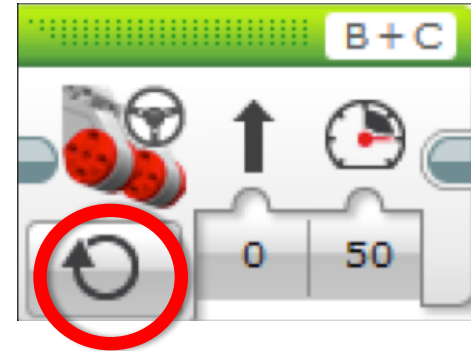

Rookie Tip: Motor On needs to be followed by another block (e.g. Wait Block)

What does Motor Off do?

CHALLENGE 1

Program your robot to move straight until you tap the sensor with your hand.

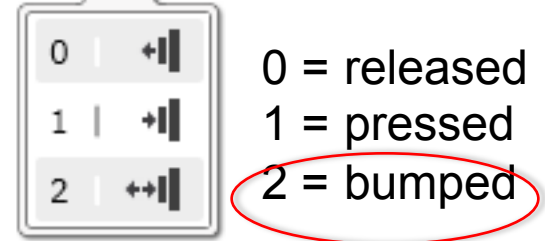
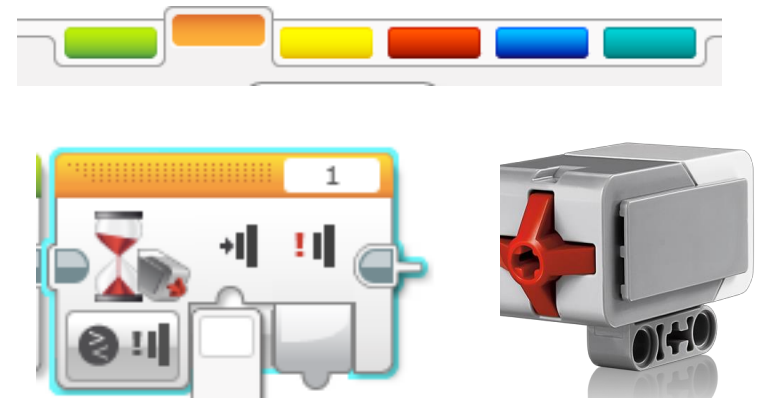
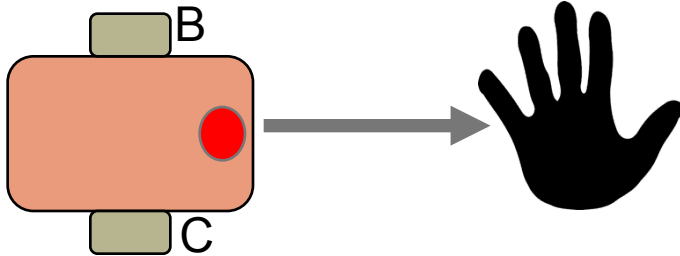

Hint: You will combine: Move Steering + Wait Block

CHALLENGE 1 SOLUTION

The goal of this program is to make your robot move straight until you touch the sensor with your hand.



Set move steering block to "on"

Set wait block to Touch-->Compare-->State

Set steering block to off with brake

CHALLENGE 2

Program your robot to move until it hits the edge of a wall. Then back up and turn right 90 degrees.

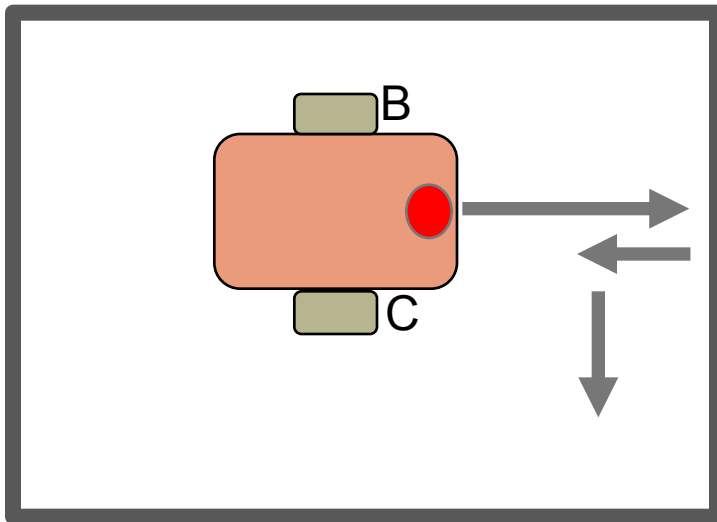

0 = released
1 = pressed
2 = bumped

Hint: You will combine Move
Steering + Turning + Wait
Block

CHALLENGE 2 SOLUTION

The goal of this program is to make your robot move until it hits the edge of a wall. Then back up and turn right 90 degrees

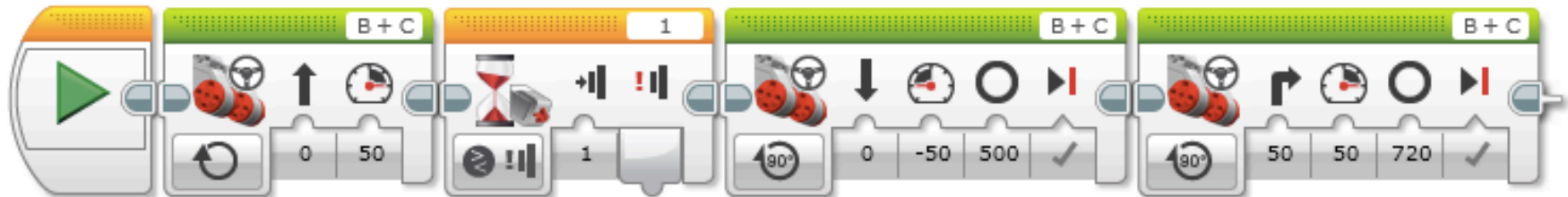

Set move steering block to "on"

Set wait block to Touch-->Compare-->State

Move backwards

Set move steering block to "degrees" and steering to 50. The 720 degrees value will have to be modified for your robot (measure using Port View)

DISCUSSION

Why did you use MOTOR ON for these challenges?

You want to read the sensor while the motor is on.

Why do we use the WAIT FOR BLOCK in these challenges?

We need to program to wait for the correct reading

What is the difference between PRESSED, RELEASED and BUMPED?

PRESSED = pushed in, RELEASED = not pushed,
BUMPED = pressed and released recently

What are some situations you might want to use each of these for?

PRESSED = running into a wall, BUMPED = tapped by hand
RELEASED = no longer touching a wall

CREDITS

- This tutorial was created by Sanjay Seshan and Arvind Seshan
- More lessons are available at www.ev3lessons.com



This work is licensed under a [Creative Commons Attribution-NonCommercial-ShareAlike 4.0 International License](https://creativecommons.org/licenses/by-nc-sa/4.0/).