

ADVANCED EV3 PROGRAMMING LESSON



Ramping Up Speed

By Sanjay and Arvind Seshan



Lesson Objectives

- Learn what ramp up means
- Learn how and when to use ramp up
- Learn how to use the Timer Block

- Prerequisites: Data Wires, My Blocks with Inputs & Outputs

Why Ramp Up

- Ramping up speed is very helpful when running fast-paced programs
- Usually, if the robot starts up with high speed, then there would be a small jolt in the beginning. The jolt may change the position of the robot.
- With the ramp up, it would start up slowly and increase speed over time (see video on the right)



New Tool: Timer Block

- The timer block is used to count time
- It is found in the Yellow (sensor tab) in the EV3 Software.
- Multiple timers are available (up to 8 timers)
- You can use the block to reset a specific timer back to 0 seconds
- You can use the block to output the time since reset...
- If you are an FLL team, you can use timers to track time or for the ramp up code in this lesson

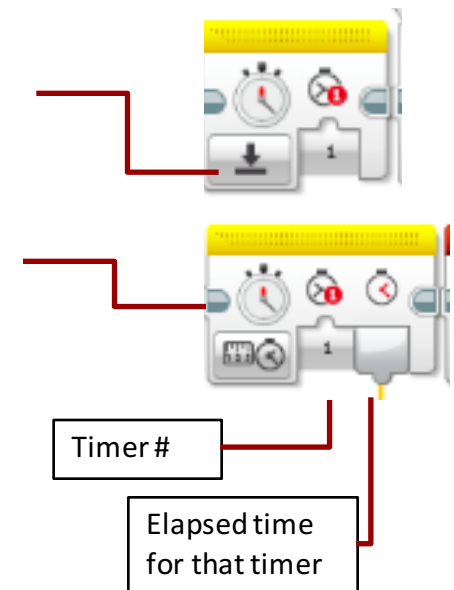

Ramp Up in 4 Easy Steps



1. Reset timer
2. In a loop, read the number of seconds passed and multiply the power by 20.
3. Still in the loop, take the result of the multiplication and connect it to the move block.
4. Repeat the Loop for 5 seconds

Base Ramp Up

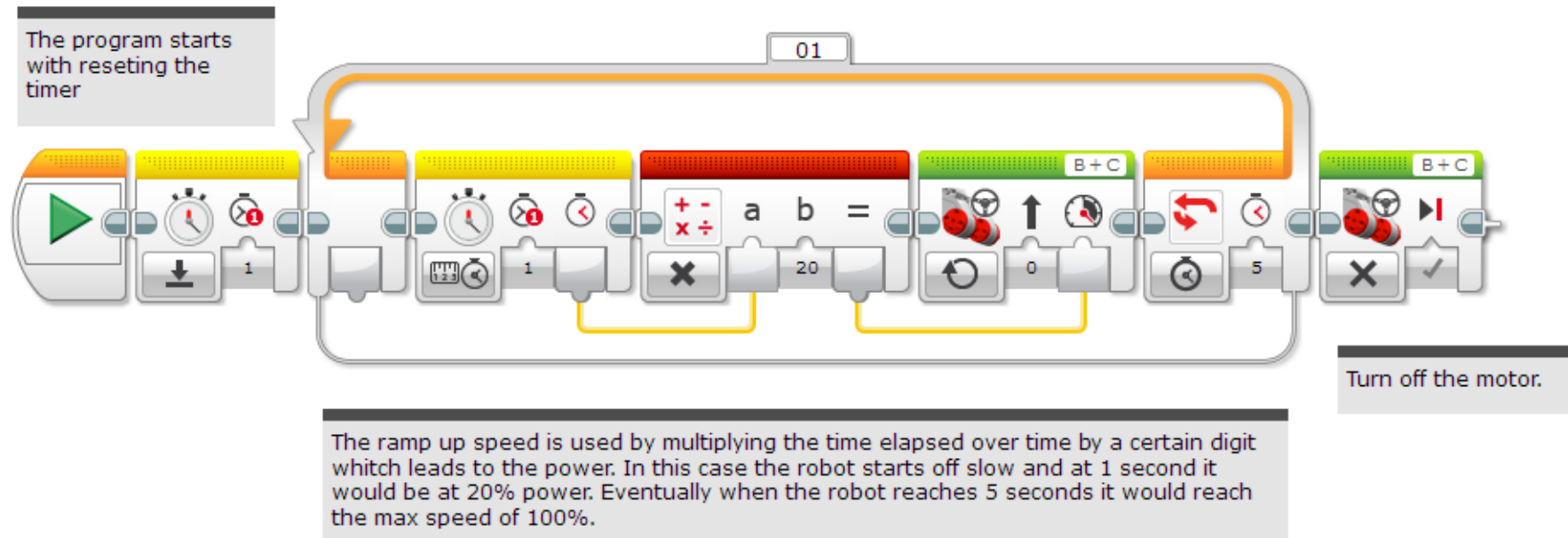

Code by Mesa Robles Robotworks. Modified by Droids Robotics

Ramp Up Challenge

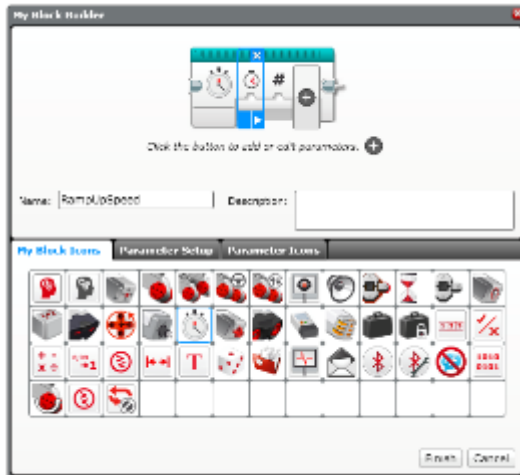

Step 1: Can you now make a ramp up program that takes 2 inputs (total duration of ramp up and how much you want the motor to ramp up per second)? Create a My Block.

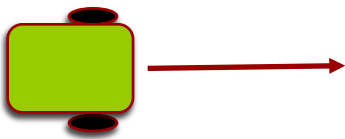

Step 2: Ramp up your robot, then move until a black line.

Wire the My Block

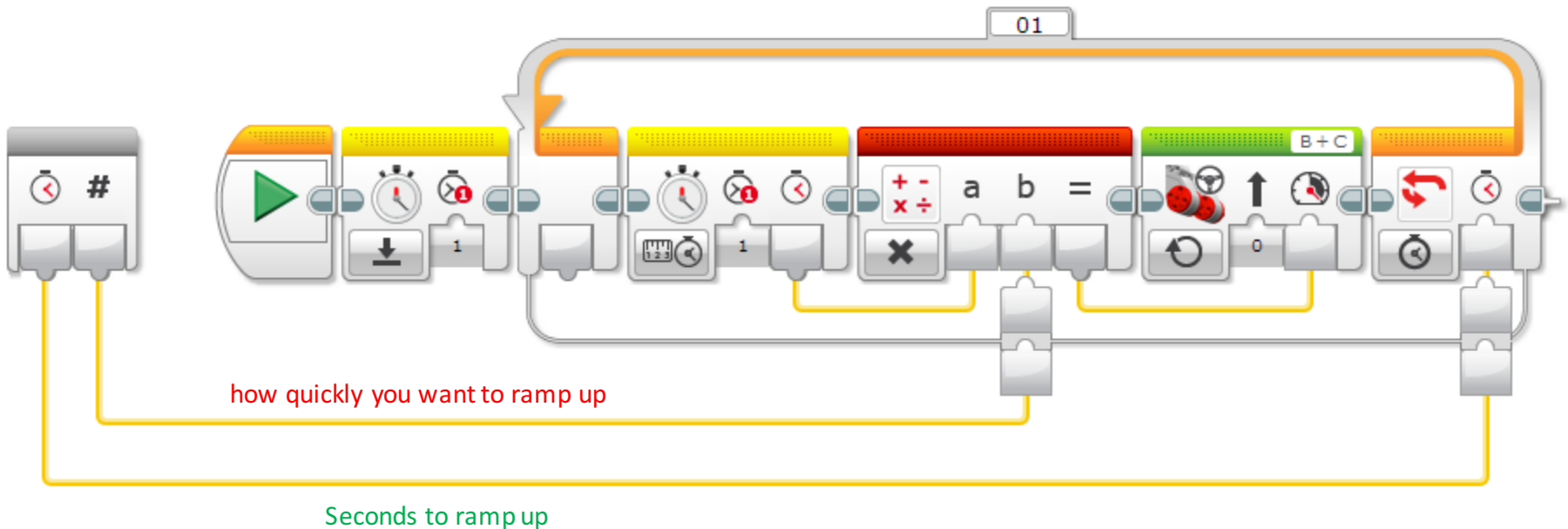

Wire the “How quickly you want to ramp up” input to the Math Block and the Seconds input to the Move Steering block

Challenge Solution

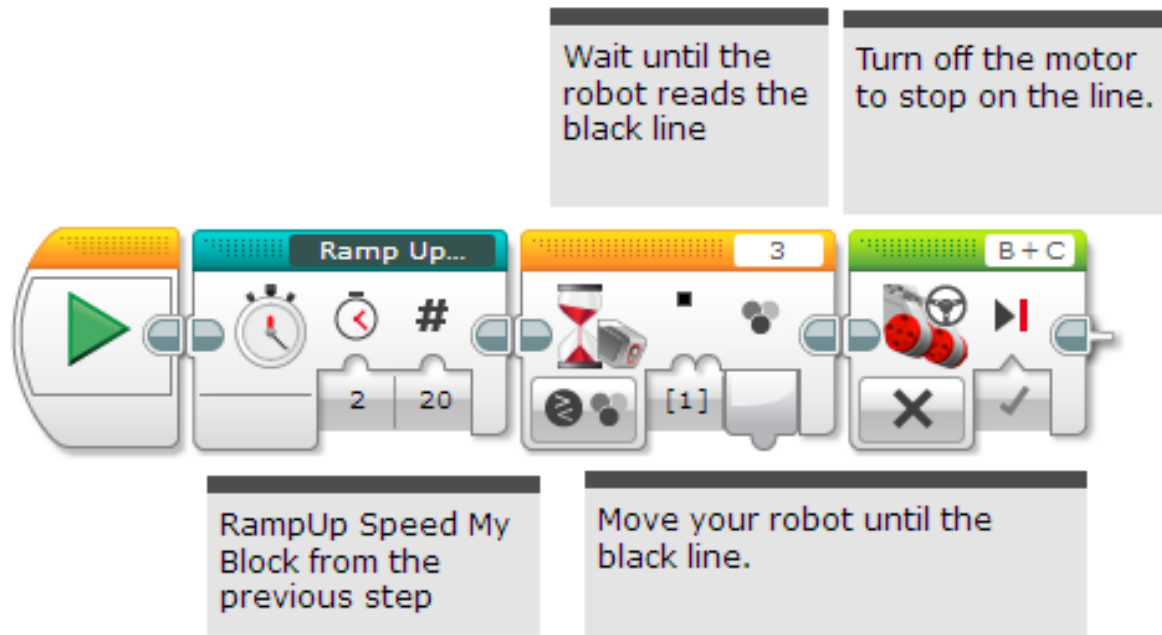

Code by Mesa Robles Robotworks. Modified by Droids Robotics

Discussion Guide

1. **What is ramping up?**

Ans. Ramping up is starting slow and getting gradually faster.

2. **Why should you bother?**

Ans. Ramping up can reduce sudden jerk in robot movement.

Next Steps



- Think about what else you might be able to use a timer block for.

Credits

- This code for this tutorial was created by Mesa Robles Robotworks (mesarobotworks@gmail.com)
- Sanjay and Arvind Seshan added content to complement the original lesson (team@droidsrobotics.org)
- More lessons at www.ev3lessons.com



This work is licensed under a [Creative Commons Attribution-NonCommercial-ShareAlike 4.0 International License](https://creativecommons.org/licenses/by-nc-sa/4.0/).